



## GRAND SLAM 950 ELECTRIC MASTHEAD ANCHOR LIGHT



Complete your electric-mount arsenal with the Grand Slam 950 Electric Masthead Anchor Light! With the simple push of a button, boaters can safely adjust the position of their Masthead Anchor Light from the comfort of the helm. Ideal for powered vessels 39' and under (12-meters and under), the GS-950 is certified for USCG-required 3 nautical miles. The GS-950 is a fully electric unit with hidden wires inside the hardtop. This mount easily installs to the surface of the hardtop and fits all top thicknesses. The GS-950 lights run on 12 volts and consists of four 3-watt LED Cree chips driven by two Mean Well drivers.

### GS-950 FEATURES & BENEFITS

- Machined / Anodized aluminum body with a light-brushed finish
- Certified for USCG-required 3-nm
- Includes tube, light and 6" lead of 20-gauge wire from the base
- 12-volt DC power supply for light
- Threaded shaft for consistent lift and descent
- Brass bearings for smooth operation
- Features breakaway pin for manual operation
- Mounts to all hardtops
- Reliable long-life LEDs
- 6-Watt Stern Light and 12-watt Anchor
- Low-draw, 0.6 amps per light
- Low-voltage 12-24VDC
- Backing Plate (BP-0850AEY) sold separately

Upper Adjustment Set Screw.  
Note: There are 2 set screws in the hole. The outer screws locks the magnetic set screw in place.

Lower Adjustment Set Screw.  
Note: There are 2 set screws in the hole. The outer screws locks the magnetic set screw in place.

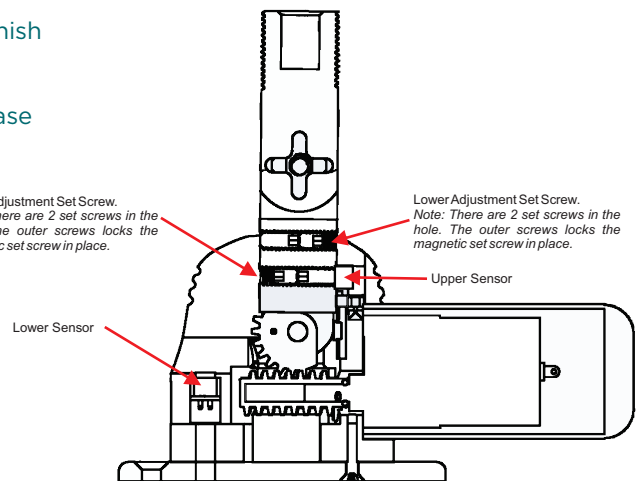

Adjustments to the arm position need to be done slowly 1/4 turn at a time. It is best practice to use an amp meter to determine when the sensor switch disables motor power. Failure to do this could result in motor failure.

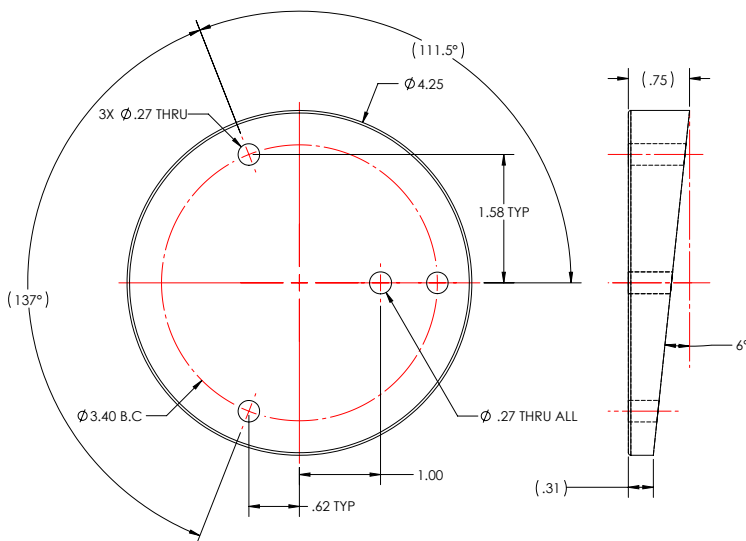

### ⚠ WARNING:

This product can expose you to chemicals including Lead, which is known to the State of California to cause cancer, birth defects or other reproductive harm. For more information go to [www.P65Warnings.ca.gov](http://www.P65Warnings.ca.gov).

PART NUMBER	DESCRIPTION	WEIGHT	UNIT	CoO	STD. PK.	UPC
GS-950	Grand Slam 950 Electric Masthead Anchor Light	3.5 lbs	Each	USA	2	631003089992

